



AIR CONDITIONING



REFRIGERATION



HEATING



JÄLLEENMYyjÄ MR.LVI LÄMPÖPUMPUHUOLTO.COM



myymälä: Muuntotie 1 D 3
01510 Vantaa
puhelin: 0300 30 80 82
e-mail: info@mrlvi.fi
avoinna: ma-pe klo 8-16

KLIKKAA TÄSTÄ VERKKOKAUPPAAN! →

mini blanc®

CONDENSATE REMOVAL PUMP

The 'ultra quick fit' Mini Blanc is designed to be fitted beneath high wall indoor units and offers easy access for future maintenance.



12L/h max. flow



10m max. rec. head
(flow rate 4L/h)



21dB(A)

KEY FEATURES

- Extra quick to fit
- Compact & discreet
- Clear removable reservoir
- Ultra quiet operation

SUITABILITY

- Up to 16kW / 54,000Btu/h
- High wall mini split systems
- ✓ **Perfect for...** Domestic use – where easy maintenance is key

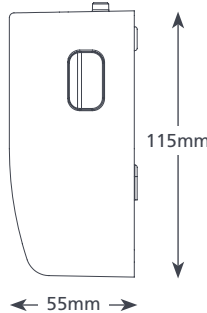
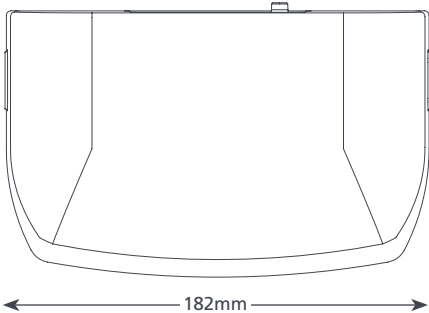

0.46 kg

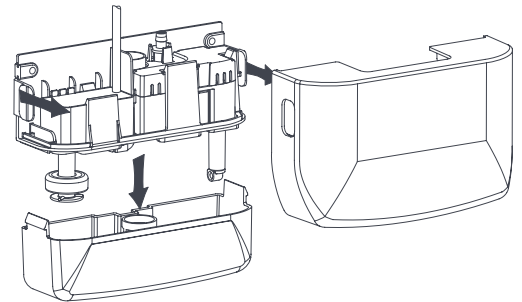

MINI BLANC SPECIFICATIONS

Max. flow	12L/h @ 0 head
Max. rec. head	10m
Tank capacity	0.24L
Sound level@1m	21dB(A)
Power supply	230 VAC, 0.11A, 19W 50/60Hz
Rated Class	Non continuous II appliance <input type="checkbox"/>
Max. unit output	16kW / 54,000Btu/h
Max. water temp	40°C / 104°F
Inlet/outlet	20mm in, 6mm out
IP Protection	IP21
Safety switch	3.0A Normally closed
Thermal protection	✓
Fully potted	Partially
Self priming	✓

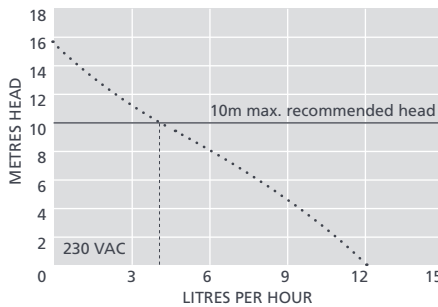

SUGGESTED XTRA ACCESSORIES

Description	Part No.
1 Amp Fuse	FP2620
Tube To Soil Stack Adaptor	FP2038
Mini Blanc Ivory Cover	FP1037

Xtra For more installation accessories take a look at our Aspen Xtra range

MINI BLANC OPTIONS

Mini Blanc (Europe)	FP1080/2
---------------------	----------

IN THE BOX

Mini Blanc pump (including hard wired 1m power cable) • Anti siphon device • Drain connector kit • Fixing kit • Install manual

- 📖 Download manual at aspenspumps.com
- ▶ View install video at aspenspumps.com

Information correct at time of going to press.



aspenspumps.com

+44 (0)1323 848842

sales@aspenspumps.com

reliable | silent | simple